

Model 1208 - 6 Meter Transverter - PC Board Error

(Note: Those undertaking this repair **do so at their own risk**. The procedures outlined located a faulty printed circuit board and worked for me. Your circumstances may differ (i.e. the problem may be another component). This procedure has not been approved by Ten-Tec, Inc. or any of its staff.)

I have recently built a Ten-Tec 1208 transverter kit for 6 metres. I had great difficulty tuning the transmit amplifier. I successfully made it to step 6-20 in the construction process but then ran into some problems. At step 6-20, with jumper TP1 installed, it's time to tune L16 and L18 to about 4 to 5 watts. The best I could do, according to my Oak Hills Research WM-2 wattmeter, was 50 mW! Further, the effect of L16 on the output was virtually zero.

After several hours of troubleshooting (I won't bore the reader with all the efforts and tests) I found the problem. The circuit board has an error. The board in my kit was **93124 6 Meter Transverter (Rev B)**. I found that the area delineated on the board for L16 had 3 holes through the board. Two holes, diagonally across from each other are for L16 itself. The 3rd hole appearing under L16, L17 and L18 has no connection. In each case the 3rd hole is plated through the board. With L17 and L18 it connects the upper surface ground plane with the lower ground plane.

On my board the 3rd hole on L16 connected the upper ground plane to a trace on the underside of the board from C37, C38, R44 and L16 effectively taking all these components to ground. A quick review of the schematic shows this is an error.

(The arrow in the figure below shows the portion of the junction grounded by the board fault.)

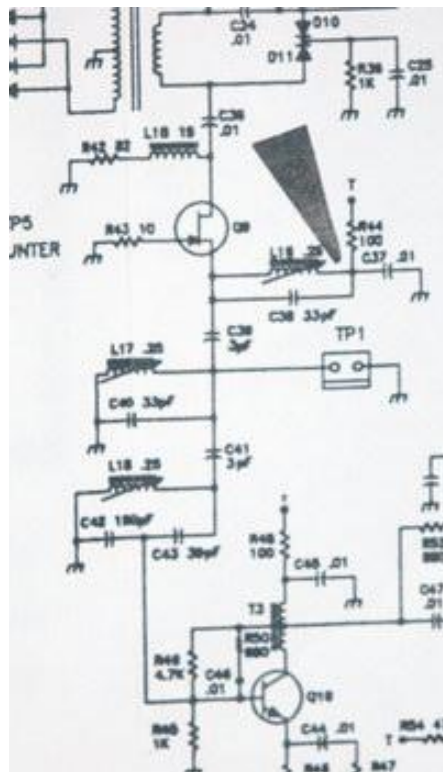

Examination of the X-Ray view shows the problem (see pad inside white circle at lower left of L16). The L17 and L18 pads connect the top ground plane to bottom ground plane BUT L16 connects the top ground plane to a trace on the under side. (Green is component side ground plane, black is underside trace, underside ground plane NOT shown.)

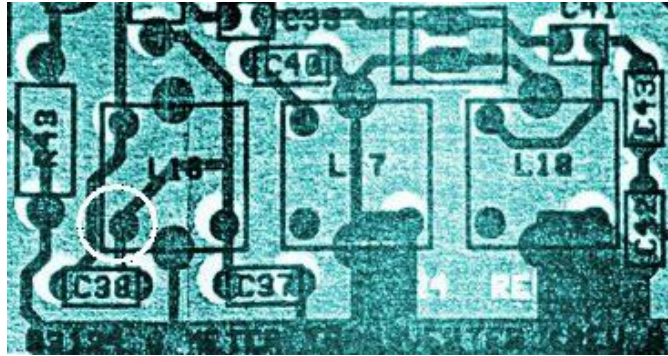

The hole in question (see photo below by the white arrow) was drilled from the top side *just deep enough* to ensure that it no longer was connected to the upper ground plane.

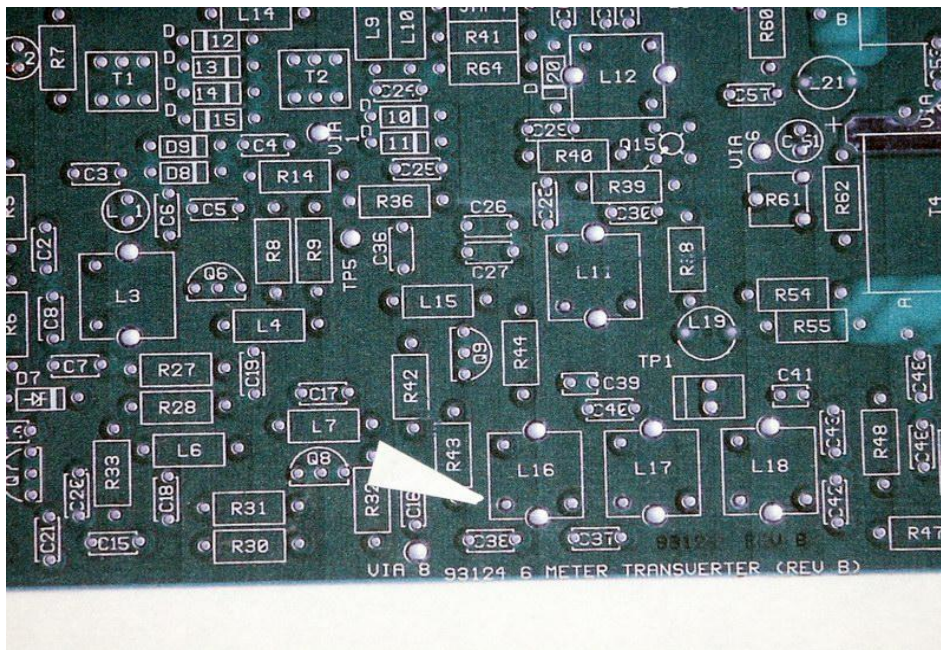

After this modification I was able to complete the alignment of the transverter. Further, I found that it was easier to peak the 3 coils (L16, L17 and L18) without installing the 150 ohm jumper across TP-1. I went through the 3 coils carefully several times to maximize the output and then peaked C34 as described in the manual.

If you're building a 1208 transverter kit you may wish to check your PC board to ensure that it is correct and does not suffer from this fault.